

Chrysler Corp. Non-Concealed Wiper with Two-Speed Motor Wiring Diagram

Chrysler Corp. Three-Speed Wiper System Wiring Diagram

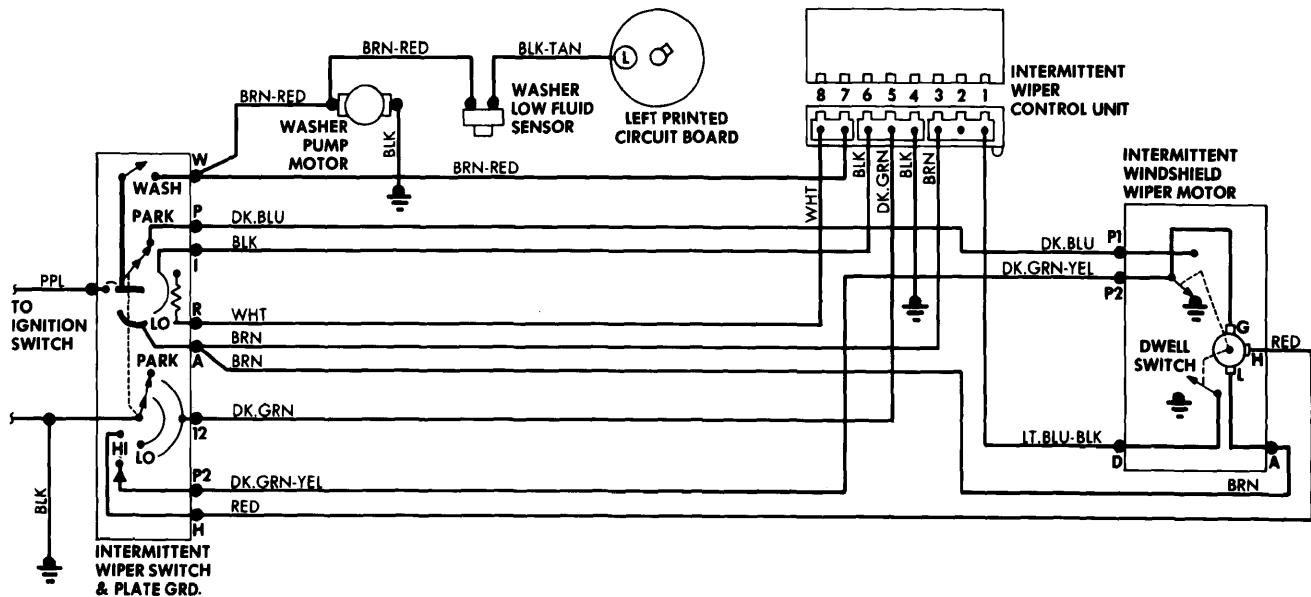

Chrysler Corp. Two-Speed Intermittent Wiper System Wiring Diagram

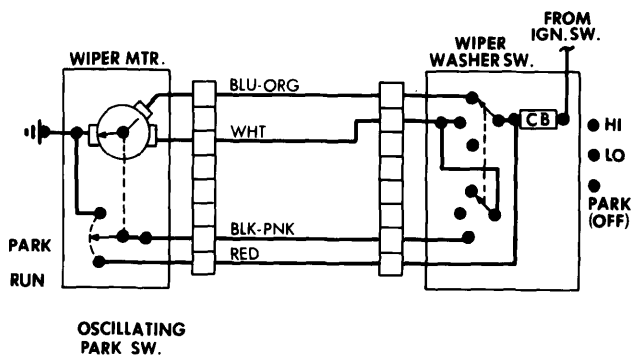

Ford Motor Co. Non-Depressed Wiper System Wiring Diagram (Exc. Intermittent Wipers) Pinto, Bobcat, Comet and Maverick

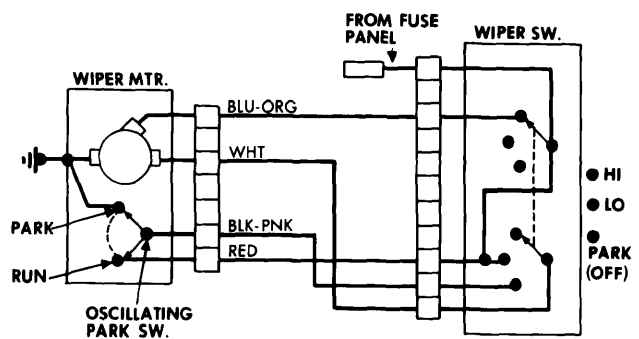

Ford Motor Co. Non-Depressed Wiper System Wiring Diagram (Exc. Intermittent Wipers) Mustang, Granada and Monarch

1977 Wiper/Washer Systems

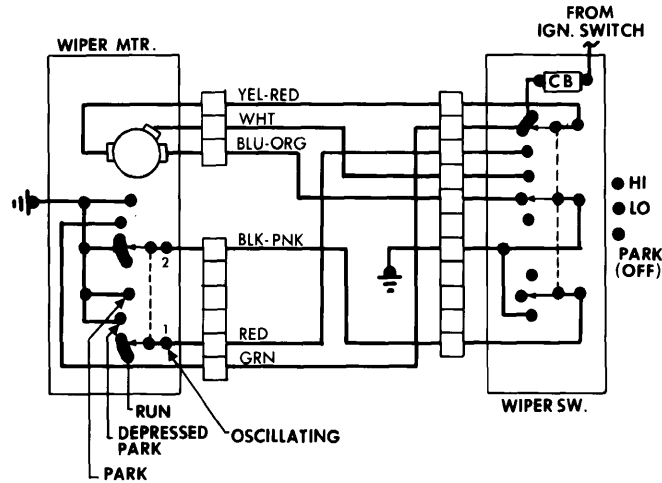

Ford Motor Co. Depressed Park Wiper System wiring Diagram
 (Exc. Intermittent Wipers) - LTD II, Cougar, Thunderbird, Ford,
 Mercury, Lincoln and Mark V

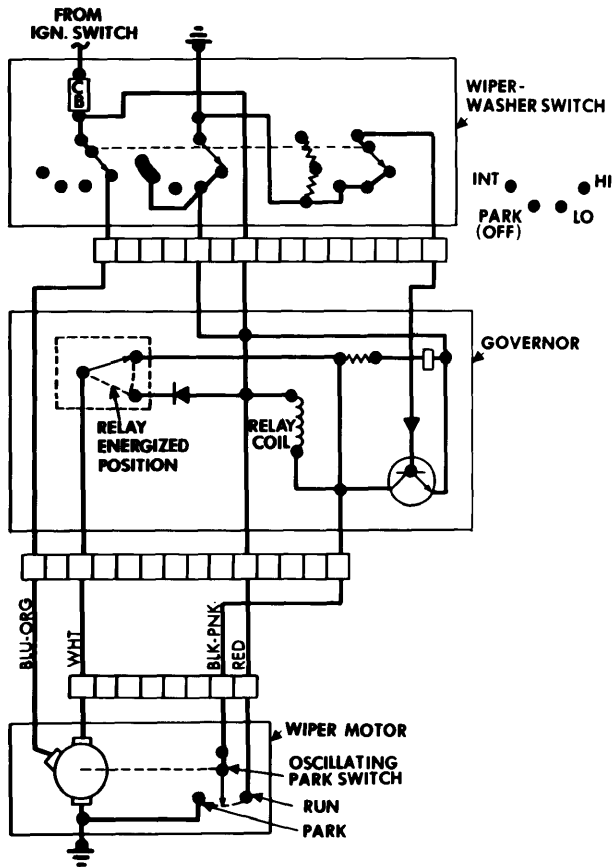

Ford Motor Co. Two-Speed Non-Depressed Intermittent Wiper System Wiring Diagram - Pinto, Bobcat, Maverick and Comet

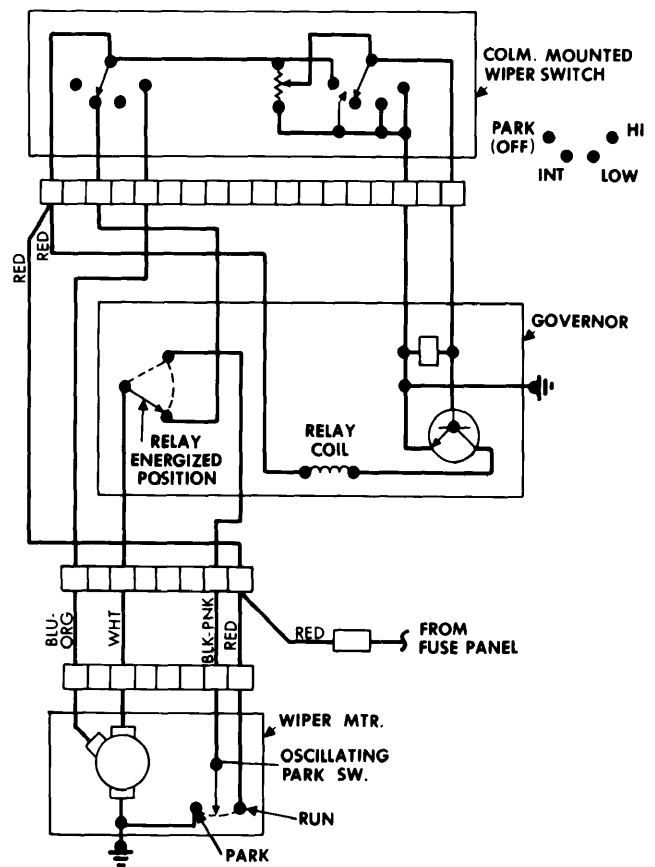

Ford Motor Co. Two-Speed Non-Depressed Intermittent Wiper System Wiring Diagram - Mustang, Granada and Monarch

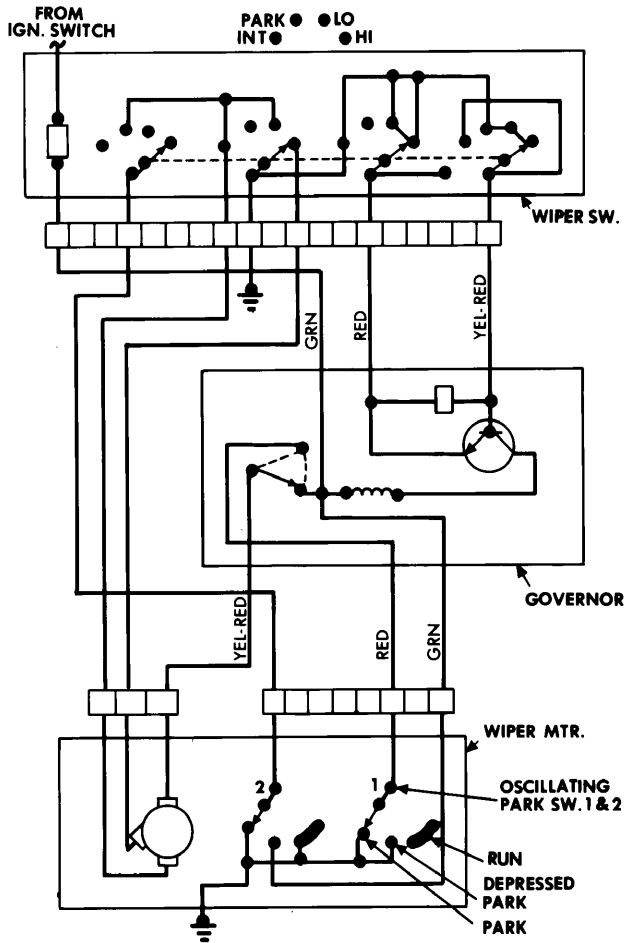

Ford Motor Co. Two-Speed Depressed Park Intermittent Wiper System Wiring Diagram - LTD II, Cougar, Thunderbird, Ford, Mercury, Lincoln and Mark V

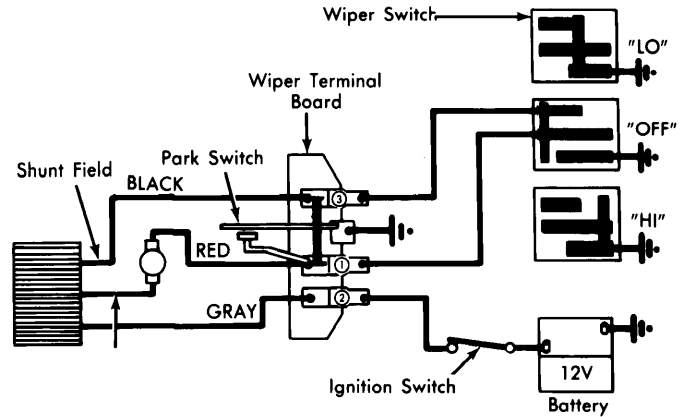

General Motors Square Motor Wiper System Wiring Diagram

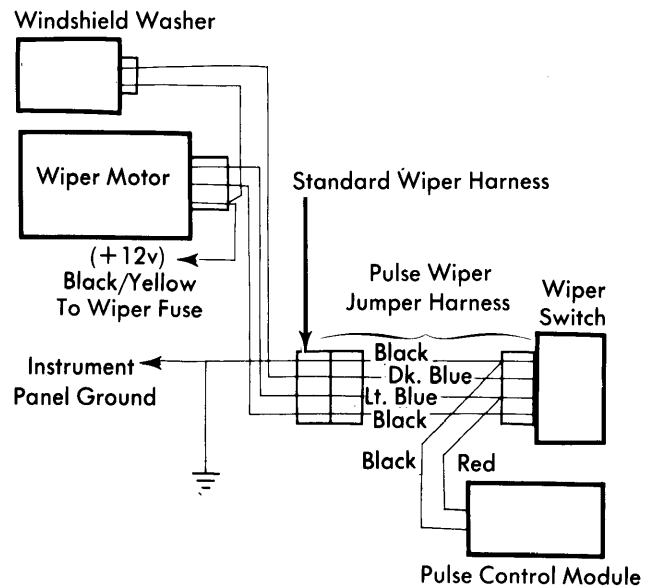

General Motors Pulse Control Wiper System Wiring Diagram

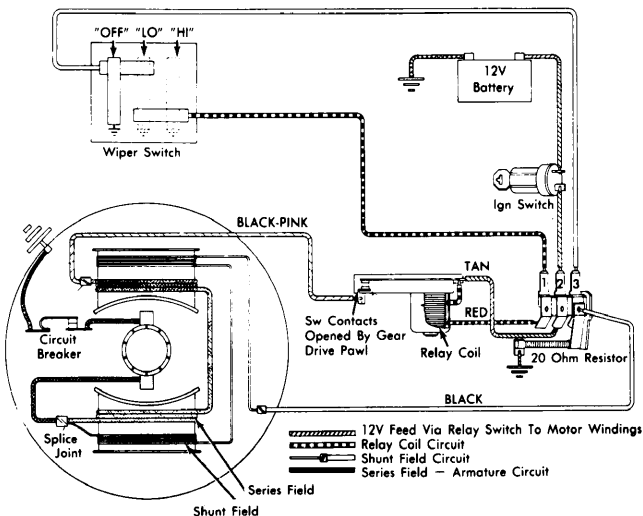

General Motors Round Motor Wiper System Wiring Diagram